



FIGURE 6.1

Chords in Shear Walls and Horizontal Diaphragms Using the "Deep Beam" Analogy

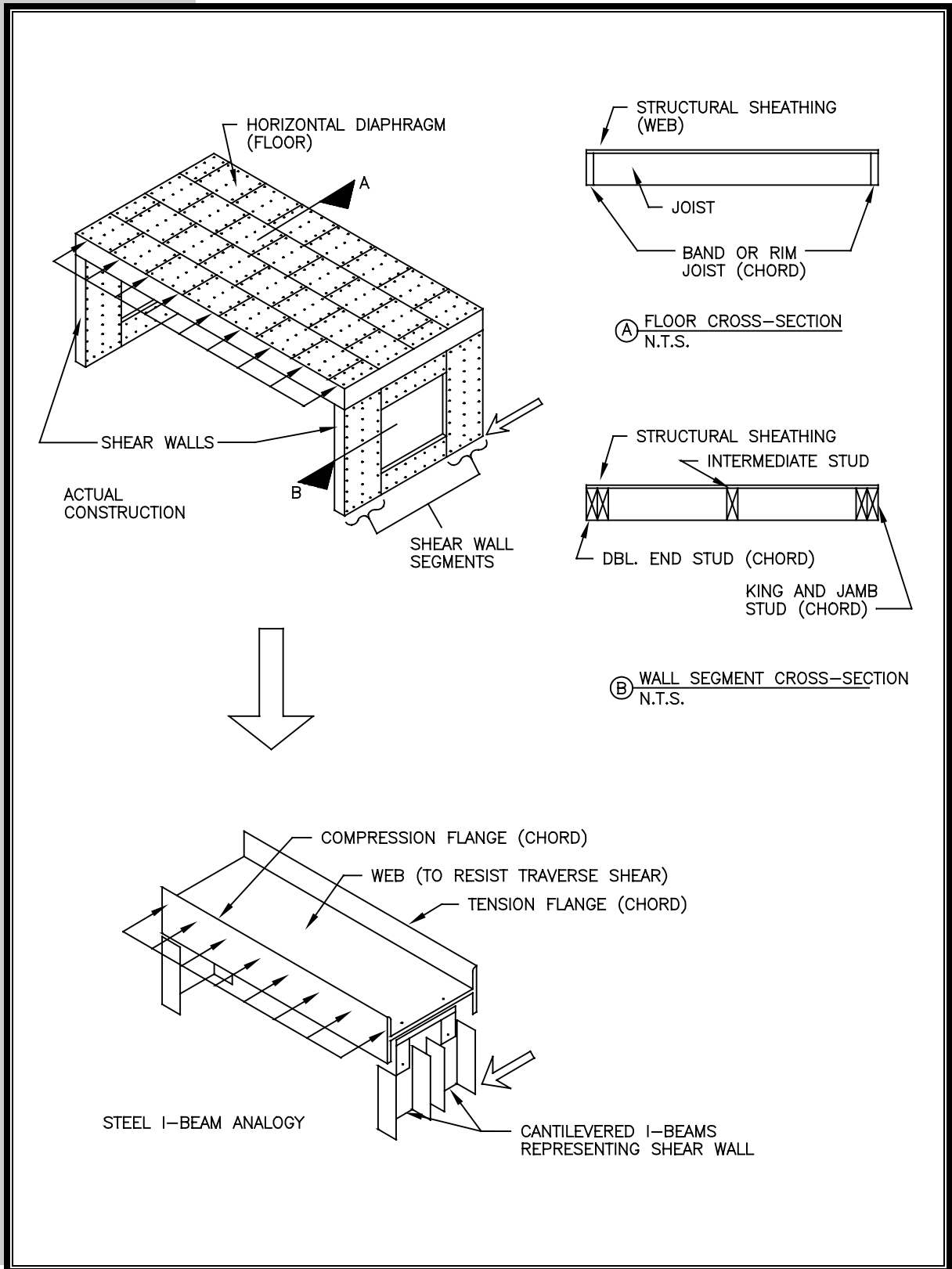



FIGURE 6.2 *Shear Wall Collector and the Composite Failure Plane
(Failure plane also applies to diaphragm chords)*

